

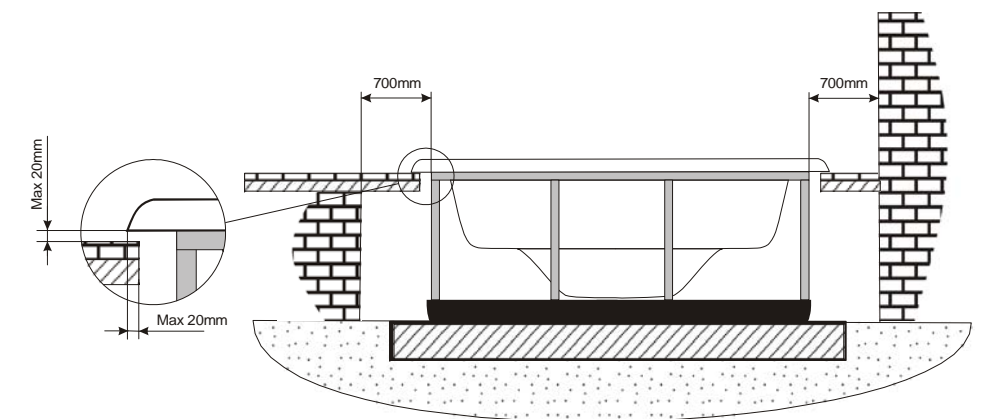

**Inground option**

**WARNING:**  
It's essential to keep a minimum clearance access of **700mm** all around.  
Minimum depth of spa hole **920 mm**.



↑  
↑  
ELECTRICAL BOARD CONNECTIONS ACCESS

According to our policy of continuous improvement, dimensions, features or components of this product can be partially or completely changed without prior notice.  
It's Customer responsibility to verify that this is the last version of the drawing

00	06/05/2015	I.Pozo	Drawing creation			
Change No.	Date	Name	Modification			
Remarks				COMMERCIAL		
Dimensions in mm. General Tolerances +/- 10mm						
Drawn	06/05/2015	I.Pozo		Part Number	Rev.	First Angle Projection
Checked	-	V.Saiz		62398	00	
Scale 1:15	General Tolerance					
Sheet 1/2	DIN 7168 ISO 2768g					

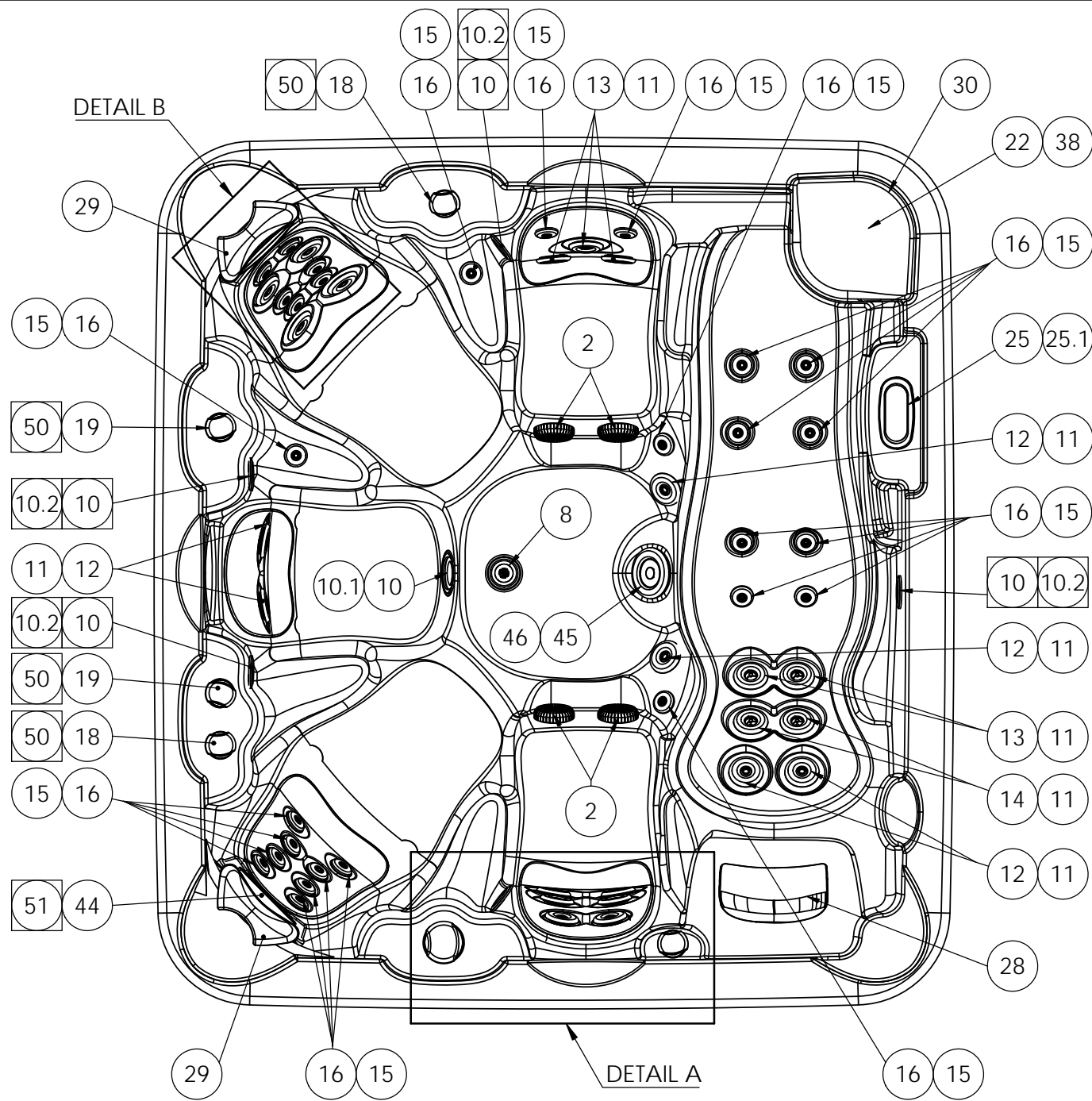

**PUMPS SPARE CODES**

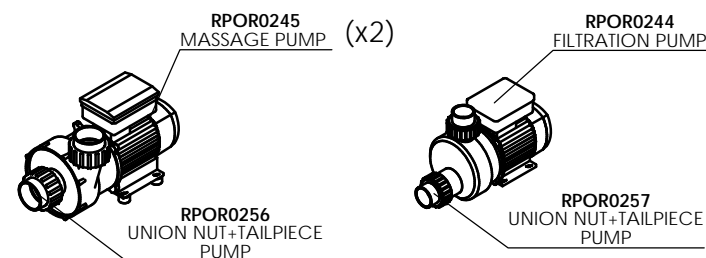

**HEATER AND DESINFECTATION SPARE CODES**

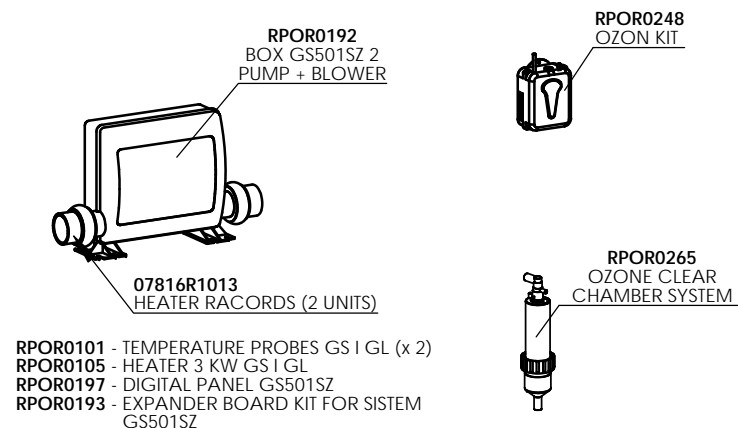

RPOR0101 - TEMPERATURE PROBES GS I GL (x 2)  
 RPOR0105 - HEATER 3 KW GS I GL (x 2)  
 RPOR0197 - DIGITAL PANEL GS501SZ  
 RPOR0193 - EXPANDER BOARD KIT FOR SISTEM GS501SZ

**PURE LINE LIGHTING SPARE CODES**

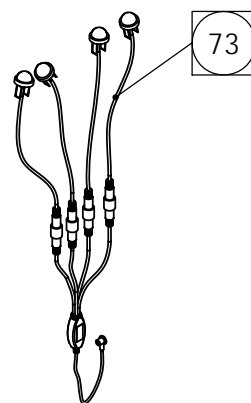

**LIGHT COMPONENTS SPARE CODES**

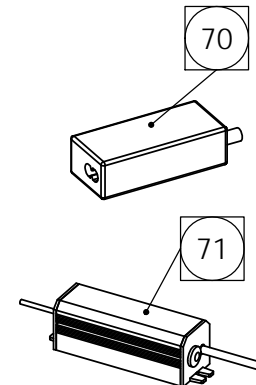

According to our policy of continuous improvement, dimensions, features or components of this product can be partially or completely changed without prior notice. It's Customer responsibility to verify that this is the last version of the drawing

ACCESSORIES			
Position Num.	Part Nº SPARE	Description SPARE	Quant.
2	RPOR0225	GREY SPA DRAIN 2" ADAPTOR SOCKET D.50	4
8	RPOR0003	GREY DRAIN SET - BODY+COVER+ASSEMBLY	1
10	RPOR0239	SPOTLIGHT LED SET RD	6
10.1	RPOR0240	MASTER LED LIGHT	1
10.2	RPOR0252	LED SLAVE LIGHT	5
11	RPOR0236	JET BODY SET RD 3"	23
12	RPOR0231	FRONTAL JET 3" STAINLESS STEEL DIRECTIONAL	14
13	RPOR0232	FRONTAL JET 3" STAINLESS STEEL 1 JET ROTO	5
14	RPOR0233	FRONTAL JET 3" STAINLESS STEEL TWIN ROTO	4
15	RPOR0235	JET BODY SET RD 2"	28
16	RPOR0230	FRONTAL JET 2" STAINLESS STEEL DIRECTIONAL	28
18	RPOR0261	VENTURY CONTROLLER SS	3
19	RPOR0263	VALVE ON-OFF 1" SS	2
20	RPOR0262	3 WAYS SS VALVE 2"	1
22	RPOR0238	SKIMFILTER RD LOW PROFILE	1
25	RPOR0241	CONTROL PANEL VL600S	1
25.1	RPOR0273	COVER DIGITAL PANEL VL600 2 JETS PUMP	1
28	RPOR0032	SMALL HEADREST GREY	1
29	RPOR0095	SMALL HEADREST - PACIFIC-ANTARTIC	2
30	RPOR0156	SKIMFILTER COVER	1
38	RPOR0247	FILTER CARTRIDGE SKIMFILTER RD	1
44	RPOR0278	SS 7" WATERFALL	2
45	RPOR0234	FRONTAL JET 5" STAINLESS STEEL DIRECTIONAL	1
46	RPOR0237	JET BODY SET RD 5"	1
49	RPOR0136	DRAIN FILL VALVE (BLACK)	1
50	RPOR0267	4 LEDS LIGHTS POINTS	6
51	RPOR0268	1 LED LIGHT POINT	4
70	RPOR0280	LEDS TRANSFORMER 5V DC	1
71	RPOR0281	LEDS CONTROLLER	1
73	RPOR0259	CABLE 4 OUTPUTS + LEDS	4

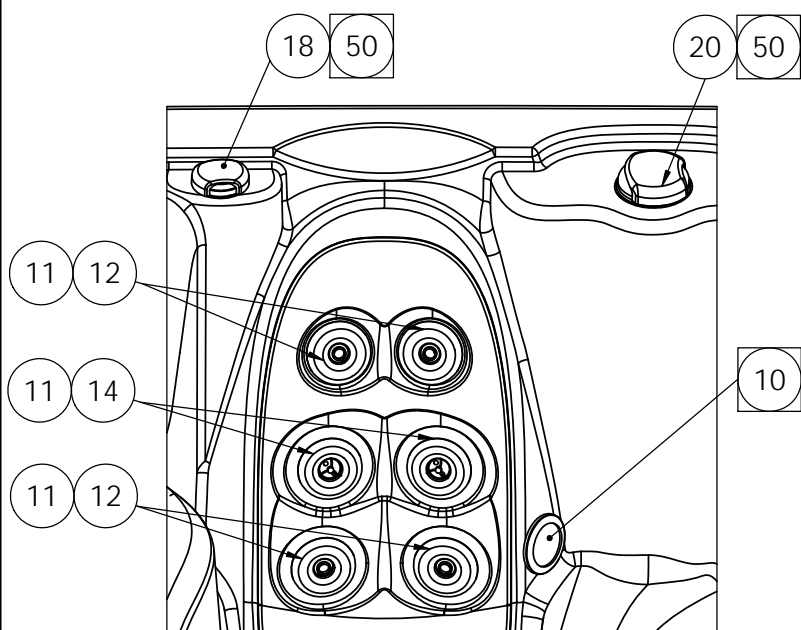

**A (1 : 10)**

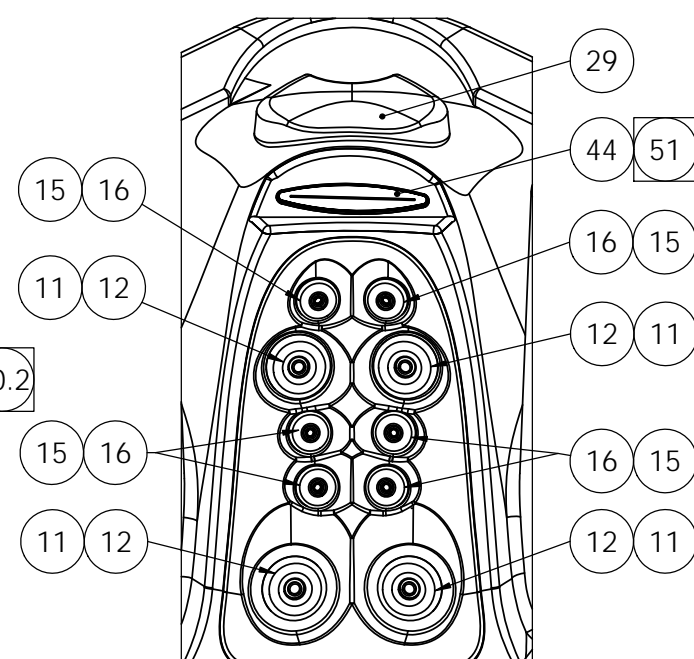

**B (1 : 10)**

00				06/05/2015	I.Pozo	Drawing creation
Change No.	Date	Name	Modification			
Remarks						
Dimensions in mm. General Tolerances +/- 10mm						
Drawn	06/05/2015	I.Pozo				
Checked	-	V.Saiz				
Scale 1:15	General Tolerance					
Sheet 2/2	DIN 7168 ISO 2768g					
			SPARE PARTS DRAWING			
			Part Number	Rev.	First Angle Projection	
			62398	00		
Property of IBERSPA S.L. Avda. Pla d'Urgell 2-8 25200 Cervera, Spain. Don't use without permission. Keep this information confidential and use it solely for the permitted purpose.						